

Manufacturer:	GE NetworX
Model Number(s):	NX-8E
Comments:	
Document Revision Date:	4/6/2006

OVERVIEW AND SUPPORTED FEATURES

The **Networx NX-8E** security panel integrates with the **OneHome** system using an RS-232 serial connection. The panel requires the P-0003 serial adapter cable to enable RS-232 communication between the **HomeBrick** and the control panel.

THE NX-8E SUPPORTS THE FOLLOWING FEATURES:

Arm – Disarm: Arm and disarm from the Viewer interface is supported for any partition. Status information is available for all partitions.

Auto Arm: Arming as a System Command from the Event Mapper is supported for any partition. By default, automatic arming is disabled in the Configurator.

Zone Status: Zone status information for all zones is properly shown in the Viewer.

History View: The history view is properly supported on any Viewer.

Bypassable Zones: You can bypass a zone in the Viewer interface. In Version 4.0 Build 346 and later, bypassable zones are auto-detected. In earlier version, enable bypass for each zone in the Configurator.

Auto Zone and Partition Detection: After a zone has been faulted the **OneHome** system will automatically detect the zone number and partition number but not the name.

INSTALLATION OVERVIEW

1. Install the security system and program the panel for the RS-232 interface.
2. Run a Cat5 wire from the **OneHome** system to the security panel and test the cable.
3. Test the security panel, zone sensors and keypads for functionality.
4. Connect the **OneHome** system to the panel electrically.
5. Configure the **HomeBrick** communication device and security panel and confirm communication between the panel and the **HomeBrick**.
6. Fault all the zones in the system. Faulting the zone sends a message to the **OneHome** system which then automatically adds the zone in the Configurator. Zones that can't be easily faulted must be added by hand. Confirm that all zones are visible in the Configurator, and then provide names for each zone and partition with the Configurator
7. Test the arming and disarming capability from a computer or touch screen and confirm history function.

CONNECTION METHODS

OPTION 1: CONNECT TO A SERIAL PORT ON THE NETWORK ASSEMBLY (MOST COMMON)

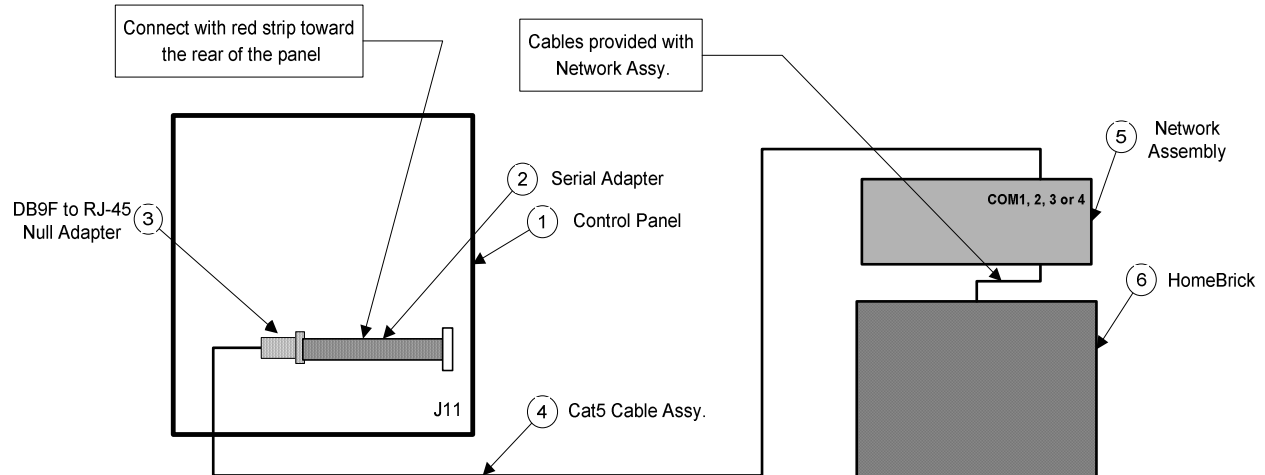

WIRING DETAILS FOR P-0003

2x5 Female Header DB-9 Male pin

1	NC
2	NC
3	3
4	NC
5	2
6	NC
7	NC
8	NC
9	5
10	(No wire)

BILL OF MATERIALS FOR OPTION 1

#	Device	Manufacturer	Part Number	Protocol	Connector Type	Notes
1	Control Panel	GE NetworX	NX-8E	RS-232	Various	
2	Serial Adapter	GE NetworX	P-0003	RS-232	DB-9 Male x (2x5 Female Header)	Connect with red strip towards rear
3	DB9F to RJ45 Null Adapter	HomeLogic	HA-CB-328	RS-232	DB-9 Female X RJ-45 Female	
4	Cat5 Cable	Installer	N/A	RS-232	RJ-45 Male X RJ-45 Male	Must terminate all 8 conductors
5	Network Assembly	Homelogic	HW-NA-18X4	RS-232	RJ-45 Female X DB-9 Female / USB	Use COM1, 2, 3 or 4
6	HomeBrick	HomeLogic	HW-HB-1080	RS-232	DB-9 Male / USB	

OPTION 2: CONNECT TO A SERIAL PORT ON THE HOMEBRICK

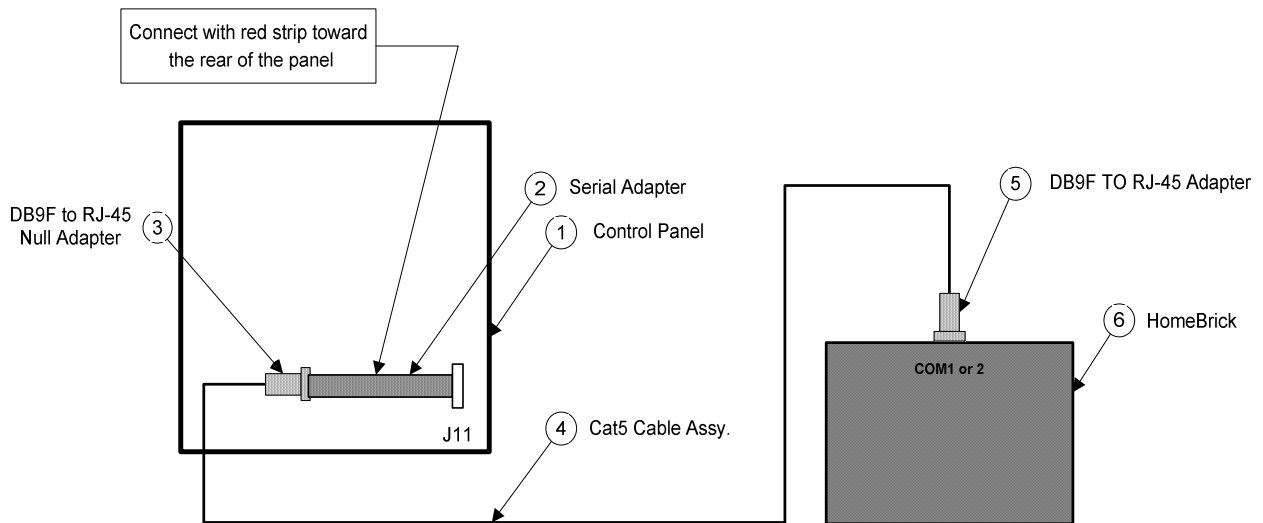

BILL OF MATERIALS FOR OPTION 2

#	Device	Manufacturer	Part Number	Protocol	Connector Type	Notes
1	Control Panel	GE NetworX	NX-8E	RS-232	Various	
2	Serial Adapter	GE NetworX	P-0003	RS-232	DB-9 Male x (2x5 Female Header)	Connect with red strip towards rear
3	DB9F to RJ45 Null Adapter	HomeLogic	HA-CB-328	RS-232	DB-9 Female X RJ-45 Female	
4	Cat5 Cable	Installer	N/A	RS-232	RJ-45 Male X RJ-45 Male	Must terminate all 8 conductors
5	DB9F to RJ45 Adapter	HomeLogic	HA-CB-308	RS-232	DB-9 Female X RJ-45 Female	
6	HomeBrick	HomeLogic	HW-HB-1080	RS-232	DB-9 Male	

OPTION 3: CONNECT TO THE ETHERNET NETWORK WITH A SERIALBRICK

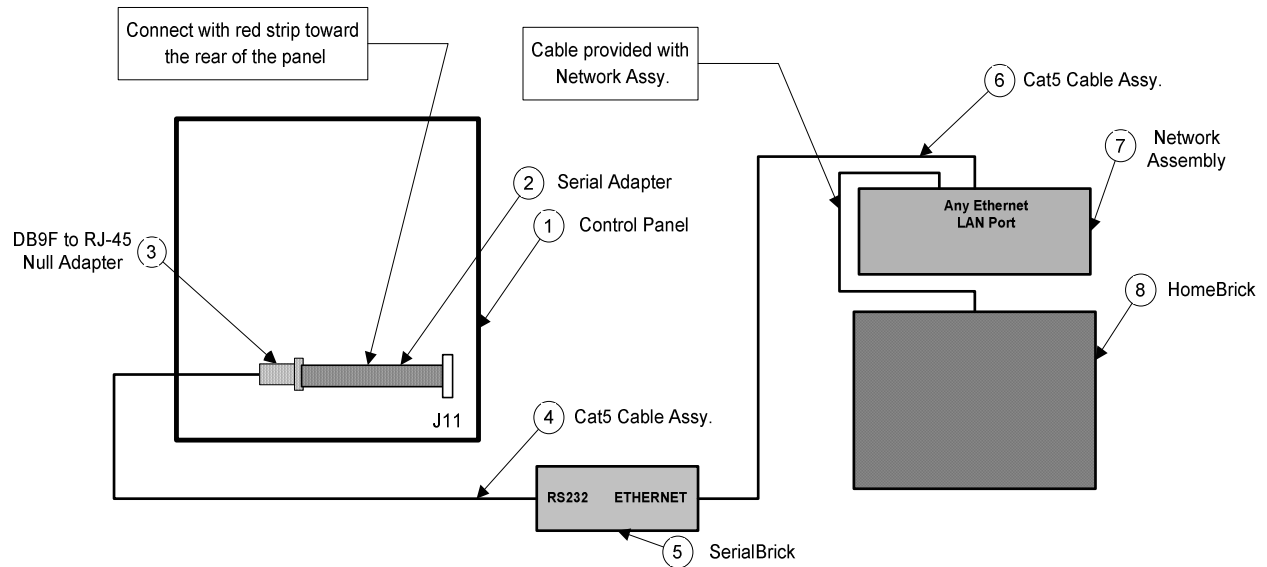

BILL OF MATERIALS FOR OPTION 3

#	Device	Manufacturer	Part Number	Protocol	Connector Type	Notes
1	Control Panel	GE NetworX	NX-8E	RS-232	Various	
2	Serial Adapter	GE NetworX	P-0003	RS-232	DB-9 Male x (2x5 Female Header)	Connect with red strip towards rear
3	DB9F to RJ45 Null Adapter	HomeLogic	HA-CB-328	RS-232	DB-9 Female X RJ-45 Female	
4	Cat5 Cable	Installer	N/A	RS-232	RJ-45 Male X RJ-45 Male	Must terminate all 8 conductors
5	SerialBrick	Homelogic	HW-EB-100	RS-232 X IP	RJ-45 Female X RJ-45 Female	
6	Cat5 Cable	Installer	N/A	IP	RJ-45 Male X RJ-45 Male	
7	Network Assembly	HomeLogic	HW-NA-18X4	IP	RJ-45 Female X RJ-45 Female	Use any available LAN port
8	HomeBrick	Installer	HW-HB-1080	IP	RJ-45 Female	

PANEL PROGRAMMING

Once the NX-8E is running properly, you need to make a few changes to its settings to integrate with the **OneHome** system. The following steps assume you have the LCD keypad. If not, refer to the NetworX documentation to understand how the values are displayed on the LED keypad.

For clarity, the following instructions use [] brackets around keys that you press and also around settings shown on the keypad.

IMPORTANT NOTE: If the segment values listed below are incorrect, the value can be changed by pushing the corresponding number on the keypad. For example: [- 2 - - - - -] can be changed to [- - - - -] by pressing the #2 button, and [- - - - -] can be changed to [- - 3 - - - -] by pressing the #3 button.

Step	Instructions	Comments
1	Press [* 8] + [9713]+[0]+[#]	Enters programming mode for the panel, module 0, using the factory default password of 9713
2	Press [207 #] +[1]+[*]	Sets the location to 207, and then sets the value for that location to 1, which enables the NX584 allowing for serial communication
3	Press [208 #] +[2]+[*]	Sets the location to 208, and then sets the value for that location to 2, setting the Baud rate to 9600
4	Press [209 #]	Sets the location to 209. Confirm that the value is [- - - - -], enabling the Home Automation Binary Protocol
5	Press [*]	Stores the data into location 209
6	Press [210 #]	Sets the location to 210 segment 1. Confirm that the value is [- 2 - - - - 7 -], enabling Interface Configuration at Power UP and Partition Status Message
7	Press [*]	Sets the location to 210 segment 2. Confirm that the value is [1 2 - - - - -], enabling System Status Message and X10 Message Received
8	Press [211 #]	Sets the location to 211 segment 1. Confirm that the value is [- 2 - 4 5 6 7 8], enabling Interface Configuration Request, Zone Name Request, Zone Status Request, Zones Snapshot Request, Partition Status Request and Partitions Snapshot Request
9	Press [*]	Sets the location to 211 segment 2. Change the value to [1 2 3 4 5 - - -], enabling System Status Request, Send X-10 Message, Log Event Request, Send Keypad Text Message and Keypad Terminal Mode Request
10	Press [*]	Sets the location to 211 segment 3. Change the value to [1 2 3 - 5 - 7 -], enabling Program Data Request, Program Data Command, User Information Request with PIN, Set

		User Code Command with PIN, Set User Authorization Command with Pin
11	Press [*]	Sets the location to 211 segment 4. Change the value to [- - - 4 5 - 7 8], enabling Set Clock/Calender Command, Primary Keypad Function with Pin, Secondary Keypad Function and Zone Bypass Toggle
12	Press [*]	Stores the data into location 211 segment 4
13	Press [2 1 2 #]	Sets the location to 212 segment 1. Confirm that the value is [192], setting the LCD Keypad Address to 192
14	Press [*]	Stores the data into location [212]
15	Press [Exit]	Exits device setup
16	Press [Exit]	Exits device setup

HOMELOGIC CONFIGURATION DETAILS

The following table provides settings used in the HomeLogic Configurator when connecting to the NetworX control panel. Please refer to the Configurator Reference Guide for more details.

In the table below:

- “<Select>” Select the appropriate item from the list (or drop-down) in the Configurator.
- “<User Defined>”, etc. Type in the desired name for the item.
- “<Auto Detect>”, etc. The system will auto detect this variable.
- “<Defined in Security System>” The security installer must provide the information to you.

Devices	Variable Name	Option 1	Option 2	Option 3																																															
Communication Devices	Name	<User Defined> (Default: Security)	<User Defined> (Default: Security)	<Auto-Detect> (See Note 1)																																															
	Type	Serial Port	Serial Port	(IP to Serial) SerialBrick																																															
	SerialBrick Name	N/A	N/A	<Select from list>																																															
	Communication Type	Standard Connection	Standard Connection	Standard Connection																																															
	Location	<User Defined> (Not Required)	<User Defined> (Not Required)	<User Defined> (Not Required)																																															
	Com Port	<Select>	<Select>	<Select>																																															
Security Panels	Name	<User Defined> (Default: GE NetworX NX-4,6,8,8E)	<User Defined> (Default: GE NetworX NX-4,6,8,8E)	<User Defined> (Default: GE NetworX NX-4,6,8,8E)																																															
	Device Type	GE NetworX NX-4,6,8,8E	GE NetworX NX-4,6,8,8E	GE NetworX NX-4,6,8,8E																																															
	Location	<User Defined> (Not Required)	<User Defined> (Not Required)	<User Defined> (Not Required)																																															
	Comm Device	<Select> (Default: Security)	<Select> (Default: Security)	<Select Auto Detect SerialBrick name above>																																															
		<table border="1"> <thead> <tr> <th>Name</th> <th>Show</th> <th>Auto</th> <th>Keys</th> </tr> </thead> <tbody> <tr> <td>Disarm</td> <td>Yes</td> <td>NO</td> <td>4</td> </tr> <tr> <td>Mode 1</td> <td>Yes</td> <td>NO</td> <td>4</td> </tr> <tr> <td>Mode 2</td> <td>Away</td> <td>Yes</td> <td>NO 4</td> </tr> </tbody> </table>	Name	Show	Auto	Keys	Disarm	Yes	NO	4	Mode 1	Yes	NO	4	Mode 2	Away	Yes	NO 4	<table border="1"> <thead> <tr> <th>Name</th> <th>Show</th> <th>Auto</th> <th>Keys</th> </tr> </thead> <tbody> <tr> <td>Disarm</td> <td>Yes</td> <td>NO</td> <td>4</td> </tr> <tr> <td>Stay</td> <td>Yes</td> <td>NO</td> <td>4</td> </tr> <tr> <td>Away</td> <td>Yes</td> <td>NO</td> <td>4</td> </tr> </tbody> </table>	Name	Show	Auto	Keys	Disarm	Yes	NO	4	Stay	Yes	NO	4	Away	Yes	NO	4	<table border="1"> <thead> <tr> <th>Name</th> <th>Show</th> <th>Auto</th> <th>Keys</th> </tr> </thead> <tbody> <tr> <td>Disarm</td> <td>Yes</td> <td>NO</td> <td>4</td> </tr> <tr> <td>Stay</td> <td>Yes</td> <td>NO</td> <td>4</td> </tr> <tr> <td>Away</td> <td>Yes</td> <td>NO</td> <td>4</td> </tr> </tbody> </table>	Name	Show	Auto	Keys	Disarm	Yes	NO	4	Stay	Yes	NO	4	Away	Yes	NO
Name	Show	Auto	Keys																																																
Disarm	Yes	NO	4																																																
Mode 1	Yes	NO	4																																																
Mode 2	Away	Yes	NO 4																																																
Name	Show	Auto	Keys																																																
Disarm	Yes	NO	4																																																
Stay	Yes	NO	4																																																
Away	Yes	NO	4																																																
Name	Show	Auto	Keys																																																
Disarm	Yes	NO	4																																																
Stay	Yes	NO	4																																																
Away	Yes	NO	4																																																
Partions	Name	<User Defined>	<User Defined>	<User Defined>																																															
	User Number	N/A	N/A	N/A																																															
	Show Partition	Yes	Yes	Yes																																															
	Areas in Partition	<User Defined> (Not Required)	<User Defined> (Not Required)	<User Defined> (Not Required)																																															
Zones	Name	<User Defined>	<User Defined>	<User Defined>																																															
	Enable Bypass	<Defined in Security System> (See Note 2)	<Defined in Security System> (See Note 2)	<Defined in Security System> (See Note 2)																																															

Notes:

1. The **Communication Devices Name** is set to **Security** by default. After you select the SerialBrick, the name will change to that specified by the SerialBrick.
2. The **Enable Bypass** variable must set to **Yes** in order to enable this feature for a zone. The zone must also be bypassable in the security panel for this feature to function.

COMMON MISTAKES

1. Failing to test the Cat5 cable assembly. It is easy to make a mistake when terminating the Cat5 cable with the RJ-45 connectors. Always use a LAN tester to check for continuity and shorts.
2. Using a Cat5 patch cable without all 8 conductors. Some Ethernet patch cables only have the 4 conductors (1,2,3,6) needed for Ethernet communications. These cables will not work as patch cables for RS-232 communications. Visually inspect the clear plastic connectors to determine if all 8 wires are present.
3. Inserting the P-0003 Serial adapter into the panel backwards. Insert the connector with the red strip towards the back.
4. Using the incorrect HomeLogic DB-9 to RJ-45 adapter to connect to the security panel hardware. Use the HA-CB-328, which provides the required NULL modem conversion. Use the HA-CB-308 to connect the Cat5 to the **HomeBrick** (Option 2 only).
5. Failing to plug the Cat5 cable assembly into the correct port. Make sure the RJ-45 connector is plugged into the same port (COM1, 2, 3 or 4) that is specified in the Configurator.
6. Failing to plug the Network Assembly serial cables and USB cables into the correct ports on the **HomeBrick**. Check that the COM port printed on the grey ribbon cables (COM1 and COM2) as well as the USB cables (COM3 and COM4) match the port numbers as printed on the **HomeBrick** label.