

<b>Manufacturer:</b>	<b>RCS</b>
<b>Model Number(s):</b>	<b>TR/TS40, TR/TS16 Thermostat</b>
<b>Comments:</b>	HomeLogic Core Module 4.0 Build 1583 or later required
<b>Document Revision Date:</b>	10/30/2009

## OVERVIEW AND SUPPORTED FEATURES

The RCS TR16 and TR40 are retrofit-able RS-485 communicating thermostats that use a 2-piece installation method to leverage existing HVAC wiring for easy install. Each thermostat consists of two parts: a wall display unit, which resembles a typical thermostat; and a HVAC Control unit. The WDU is installed using existing HVAC wires at the desired location, and connected to the HVAC Unit back box via the existing 4-wire run. All new wire connections can then be made the HVAC unit without running new wires to each thermostat location. The TR16/TR40 thermostats support 2-stage heat/2-stage cooling in a conventional gas or electric install, and 3-stage heat/2-stage cool in a heat pump setup. The TS16 and TS40 are variants of the TR16/TR40 that can be used with an HVAC Zone Controller that adds independent zone control via the use of associated dampers for improved efficiency and distribution. See RCS for full details.

Independent TR16/TR40 installs, and installs using the TS16/TS40 with ZCV series zone controllers are compatible with external RS-485 or RS-232 control from HomeLogic, and provide reliable two-way control and feedback.

### RCS THERMOSTATS SUPPORT THE FOLLOWING FEATURES:

**Temperature Control:** Temperature control can be managed by schedules tied to house modes or by manual control based on time (Timed Temporary Hold, Temporary Hold and Permanent Hold).

**Mode Control:** The climate system can be set to run in the following heating and cooling modes: **Heat** only, **Cool** only, **Auto Heat Cool (TR40 only)** or **Off**. In addition, systems that have a fan can be set to run in **Automatic** mode or **Continuous** mode.

**History View:** The history view shows the inside temperature, outside temperature, unit run and fan run times, and cooling and heating setpoints.

**Schedule Control:** Multiple schedules may be set up, and are automatically tied to the house mode.

**Zone Control:** Multi-zone "Smart Damper/Vent" systems using the RCS ZCV series of zone controllers are compatible with HomeLogic.

**Remote Sensors:** Outside Temperature can be read from RCS climate systems.

### RCS THERMOSTATS DO NOT SUPPORT THE FOLLOWING FEATURES:

**Mode Control:** Auto Heat Cool is not available for external control on the TR16 thermostats.

**Message Features:** Message features supported by RCS for display of text based messages on the WDU readout are not supported in HomeLogic.

**Humidity:** No humidity features or sensors are supported with RCS climate systems.

**Note:** The TS16 and TS40 are equivalent models to the TR16 and TR40, sold for use with Zoned Systems. They do not include the HVAC controller hardware, as this is part of the ZCV Series controller.

## INSTALLATION OVERVIEW

### CONVENTIONAL SYSTEM WITH 8AH485D OR 485PB RS485 WIRING HUB

1. Run Cat5 or 18/4 cable from the Wall Display Unit location to the Control Unit location for new installs. Retrofit installs may use existing 4-wire cable.
2. If possible, mount the HVAC Control Units and the Wiring Hub in the same location, as this will reduce wiring labor and facilitate system debugging.
3. Run Cat5 or 18/4 cable from the Control Units to the Wiring Hub, and run appropriate control cable from the Control Units to the heating and cooling equipment. Consult the HVAC equipment/RCS documentation for cabling requirements.
4. Run Cat5 from the Wiring Hub back to the Network Assembly of the **OneHome** system.
5. Mount and connect the Wall Display Unit, the Control Unit and the Wiring Hub electrically using the diagrams provided.
6. **Recheck the wiring at the Wall Display Unit, the Control Unit and the Wiring Hub.**
7. Install and power up the thermostats one at a time. Program the thermostats as outlined in the thermostat programming section, noting the thermostat ID number.
8. Test the thermostat and climate system to ensure that the thermostats correctly turn on the appropriate heating or cooling equipment, and open or close the appropriate valves / dampers.
9. Connect the **OneHome** system to the RCS thermostats electrically. See the wiring diagrams.
10. Configure the **OneHome** system for the thermostats and confirm communication between the thermostats and the **HomeBrick**.
11. Test the system by changing the set points, modes and schedules on the viewer and various thermostats, confirming that the various components in the system respond as expected.

### ZONED SYSTEM USING A ZCV-SERIES ZONE CONTROLLER

1. Run Cat5 or 18/4 cable from the Wall Display Unit location to the Zone Control Unit location for new installs. Retrofit installs may use existing 4-wire cable.
2. Run appropriate control cable from the Zone Control Unit to the heating and cooling equipment. Consult the HVAC equipment documentation for cabling requirements.
3. Run Cat5 from the Zone Controller back to the Network Assembly of the **OneHome** system.
4. Mount and connect the Wall Display Unit, the Zone Control Unit and the 485 Converter (if required) electrically using the diagrams provided.
5. **Recheck the wiring at the Wall Display Unit, the Zone Control Unit and the RS485 Converter.**
6. Install and power up the thermostats one at a time. Program the thermostats as outlined in the thermostat programming section, noting the thermostat ID number.
7. Test the thermostat and climate system to ensure that the thermostats correctly turn on the appropriate heating or cooling equipment, and open or close the appropriate valves / dampers.
8. Connect the **OneHome** system to the RCS thermostats electrically. See the wiring diagrams.
9. Configure the **OneHome** system for the thermostats and confirm communication between the thermostats and the **HomeBrick**.
10. Test the system by changing the set points, modes and schedules on the viewer and various thermostats, confirming that the various components in the system respond as expected.

# CONNECTION DIAGRAMS – CONVENTIONAL SYSTEM

## OVERVIEW

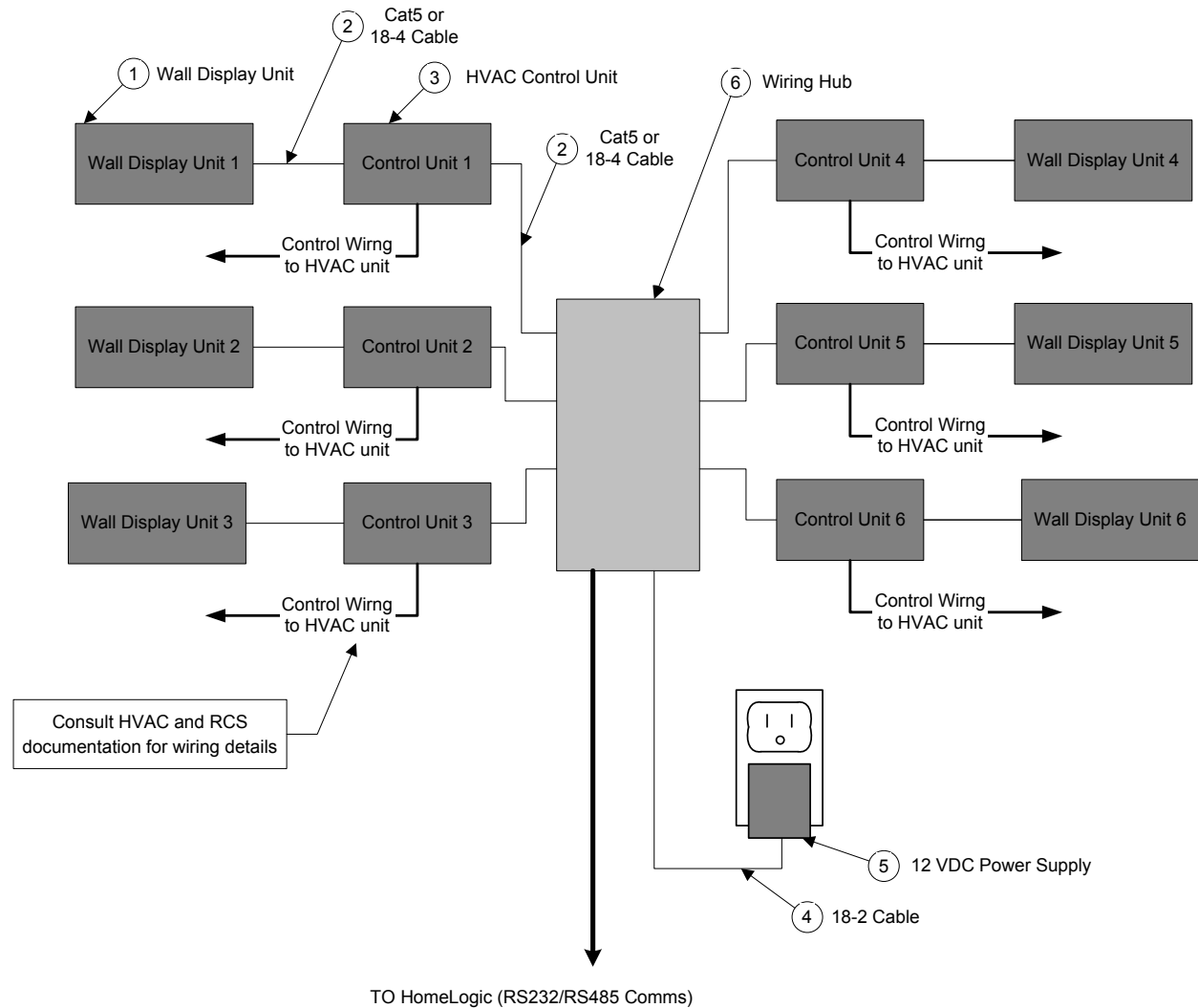

## BILL OF MATERIALS

#	Device	Manufacturer	Part Number	Protocol	Connector Type	Notes
1	Wall Display Unit	RCS	TR16 or TR40	Proprietary	Terminal Strip	The TR16/TR40 includes the Wall Display Unit and the HVAC Control unit
2	Cat5 or 18-4 Cable	Installer	N/A	Various	None	Cat5 cable is preferred, though 18-4 will work
3	HVAC Control Unit	RCS	TR16 or TR40	Proprietary X RS-485	Terminal Strip	The TR16/TR40 includes the Wall Display Unit and the HVAC Control unit
4	18-2 Cable	N/A	N/A	N/A	Terminal Strip	
5	12 VDC Power Supply	Various	(See Note)	N/A	Terminal Strip	Calculate amperage required before purchase. See RCS docs.
6	Wiring Hub	RCS	485PB	RS-485 X RS-232	Terminal Strip/DB9 Female	Use the 485PB for short wire runs for 1-2 Thermostats
	<b>OR</b>					
6	Wiring Hub	RCS	8AH485D	RS-485 X RS-232	Terminal Strip/Terminal Strip or RJ45 F	Star Wire Topology 8-Channel 485 x 1-channel RS485 or RS232

NOTE: SOME WIRING CONFIGURATIONS MAY ALSO REQUIRE HA-CB-307 DB9M-TO-RJ45F (STRAIGHT THRU) ADAPTERS.

## WIRING DIAGRAM 1: DETAIL OF 485PB WIRING

Note: Per RCS Documentation, the 485PB unit is intended for 1 or 2 thermostats with short wiring runs. For larger jobs, use the 8AH485D: see below for wiring diagrams.

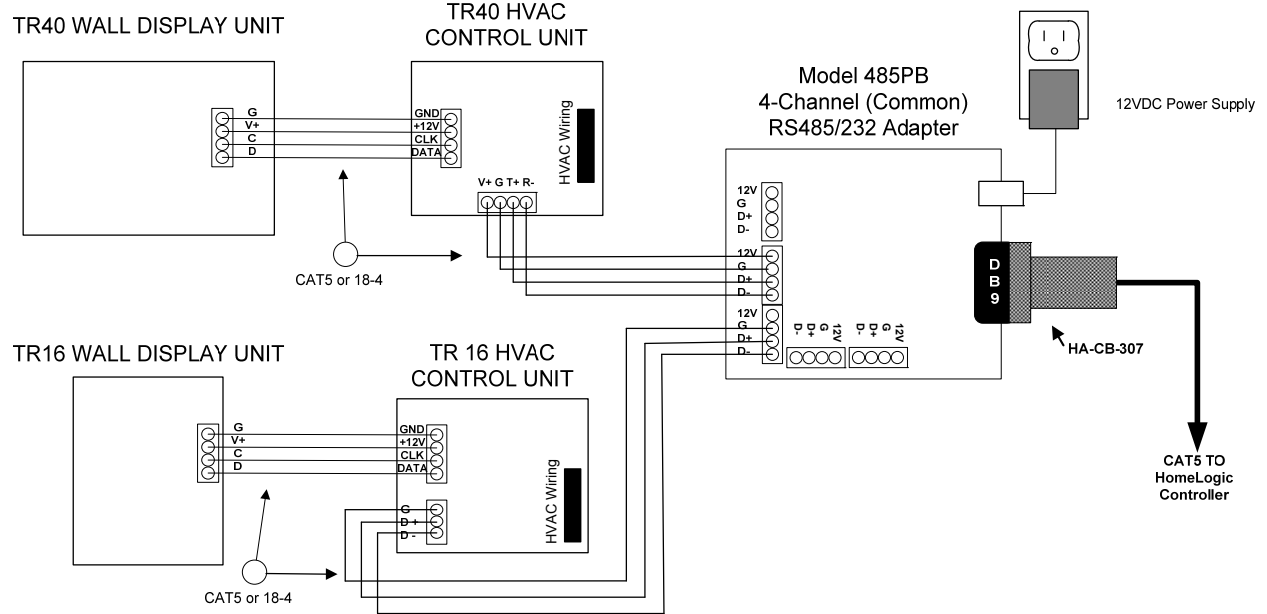

**Notes:**

1. If supplying power from the 485PB to the individual HVAC Control Units, **do not** attach power supplies at the HVAC Control Units. See RCS for details. (TR40)
2. If wiring power at HVAC Control Units, it is not necessary to connect 12V (TR40)
2. Use Cat 5 cable where practical. 18-4 cable will work if needed.
3. CAUTION: Do not miswire the Wall Display Unit: damage may result.
4. 485PB uses a common 485-bus and is only intended for 1 -2 thermostats with short wiring runs. See RCS documentation for details.

## WIRING DIAGRAM 2A: DETAIL OF 8AH485D WIRING

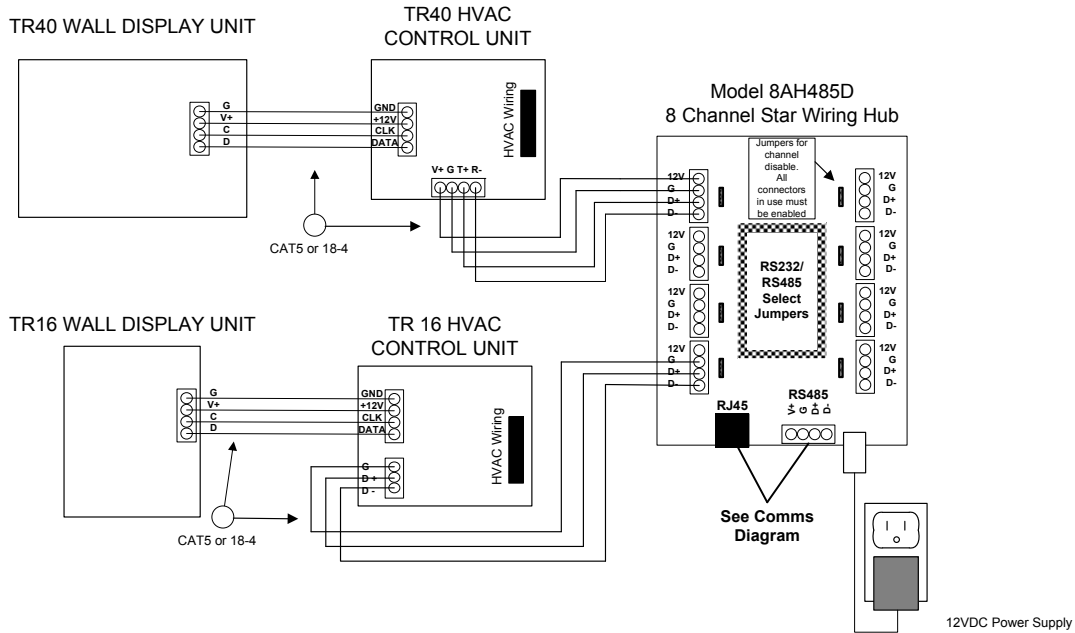

### Notes:

1. If supplying power from the 8AH485D to the individual HVAC Control Units, **do not** attach power supplies at the HVAC Control Units. *Max power draw from 8AH485D is 1000mA. Max power per channel is 200mA.*
2. If wiring power at HVAC Control Units, it is not necessary to connect 12V.
3. CAUTION: Do not miswire the Wall Display Unit; damage may result.
4. 8AH485D is a star wiring topology board. No termination is required if wiring a single stat to a single connector. If you have multi-drop connection behind a terminal, follow standard termination procedures. See RCS documentation for details.

## WIRING DIAGRAM 2B: DETAIL OF 8AH485D COMMUNICATION WIRING

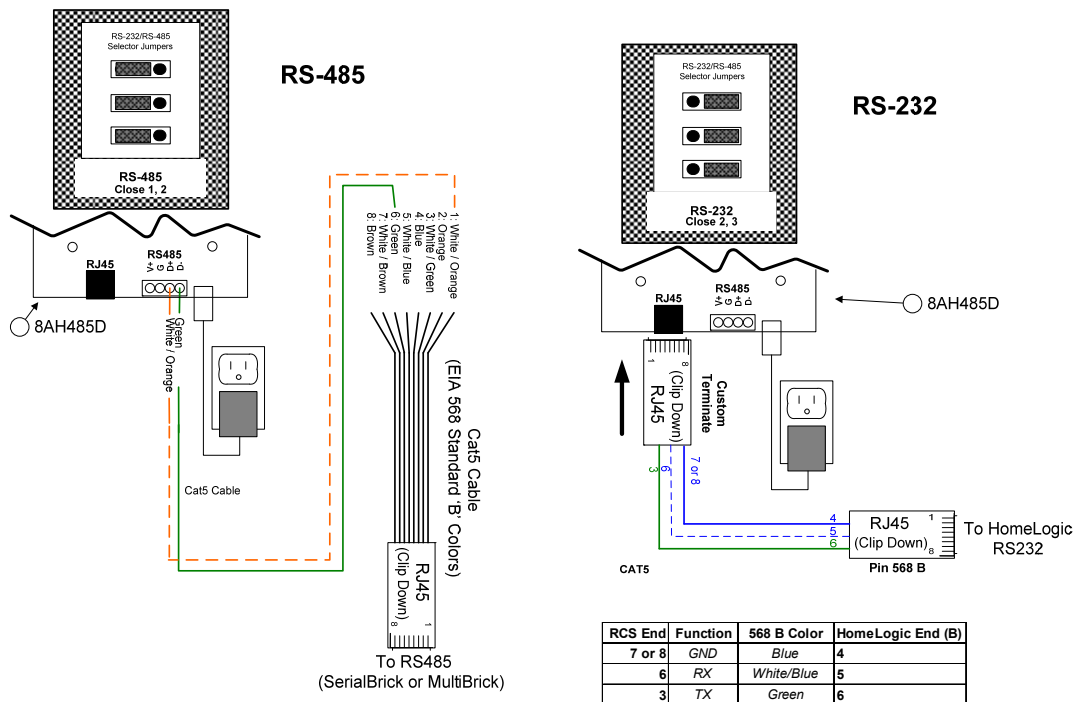

# CONNECTION DIAGRAMS – ZONED SYSTEM

## OVERVIEW

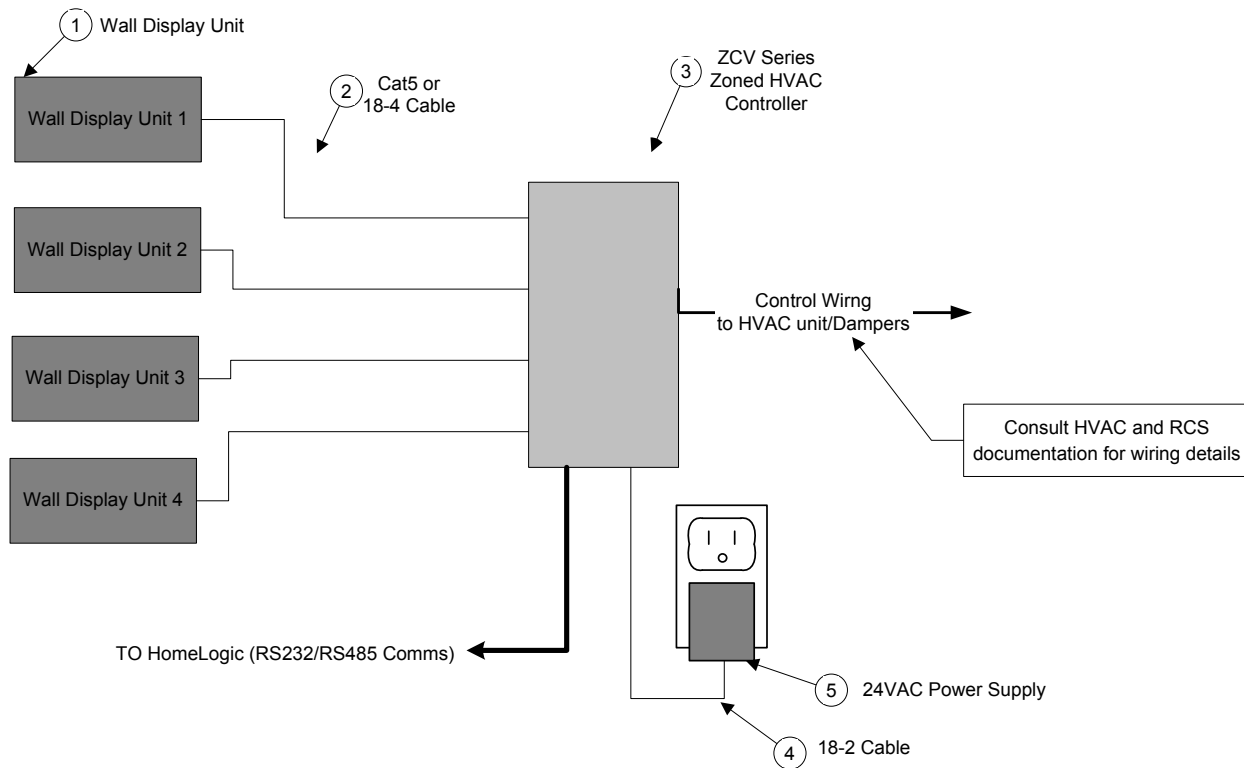

## BILL OF MATERIALS

#	Device	Manufacturer	Part Number	Protocol	Connector Type	Notes
1	Wall Display Unit	RCS	TS16 or TS40	Proprietary	Terminal Strip	
2	Cat5 or 18-4 Cable	Installer	N/A	Various	None	Cat5 cable is preferred, though 18-4 will work
3	Zoned HVAC Controller	RCS	ZCVx	Proprietary XRS-485	Terminal Strip	x=number of zones
4	18-2 Cable	N/A	N/A	N/A	Terminal Strip	
5	24VAC Power Supply	Various	(See Note)	N/A	Terminal Strip	Calculate amperage required before purchase. See RCS docs.

**NOTE: SOME WIRING CONFIGURATIONS MAY ALSO REQUIRE HA-CB-307 DB9M-TO-RJ45F (STRAIGHT THRU) ADAPTERS.**

### WIRING DIAGRAM 3: DETAIL OF ZONED HVAC CONTROL SYSTEM

TS40 WALL DISPLAY UNIT

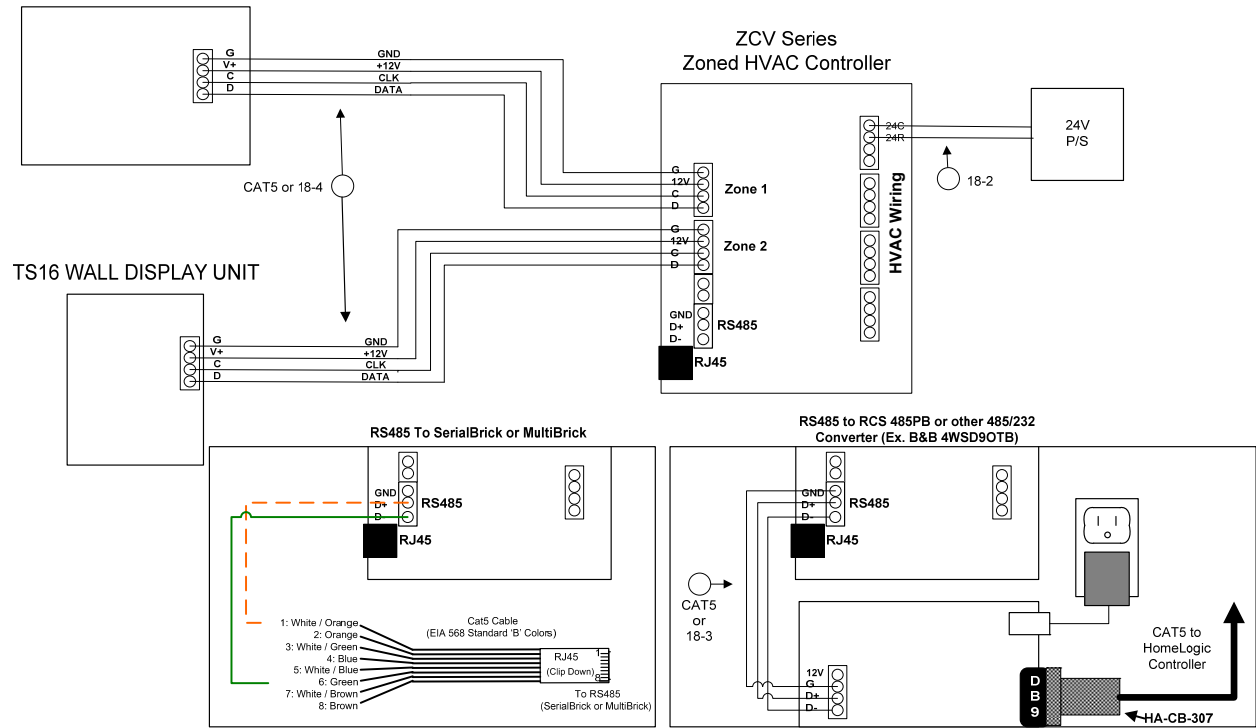

**NOTE:**

1. Zoned RCS systems using the ZCV Series HVAC Controllers must use the TS-40 or TS-16 WDU's. They cannot use standard thermostats. See RCS documentation for details.
2. The ZCV Series Controllers require at least one TS-40 for programming. See RCS documentation for details.
3. You must connect a 24v AC power supply to the ZCV unit. Calculate the amperage based on max damper load. See RCS documentation for details.

## THERMOSTAT PROGRAMMING

Once the thermostats are powered up and running properly, you need to make a few changes to the thermostat settings to integrate with HomeLogic. **Other than the changes listed below, follow standard RCS programming procedures: all TStats and Zone Controllers must be properly configured for standalone operation prior to integration in HomeLogic.**

### TR16 STANDARD THERMOSTAT SETUP

The changes outlined below assume that you are starting with a factory default thermostat. These changes then will put the thermostat into a standard HomeLogic setup.

Step	Instructions	Comments
1	Press [Mode] and then [Fan] until SU appears on the display. Release the buttons and <b>Ad</b> will appear	Places the thermostat into <b>Setup Mode</b> .
2	Press [Up] or [Down] until the desired <b>Address Number</b> appears.	Sets the <b>Address</b> of the thermostat
3	Do nothing for 3 seconds until the display <b>Exits</b> the setup mode	Exit the setup mode.

### TR40 STANDARD THERMOSTAT SETUP

The changes outlined below assume that you are starting with a factory default thermostat. These changes then will put the thermostat into a standard HomeLogic setup.

Step	Instructions	Comments
1	Press [Menu] (leftmost button) to enter the Thermostat Menu.	Unit will display the basic menu, with users settings and schedules.
2	Press and hold the center two buttons until the Thermostat enters the Installer Settings.	Unit will display the installer menu with service mode, network settings etc.
3	Use the [Up] and [Down] arrows to navigate to <b>Network Settings</b> , then press the right most button to [Select].	Unit will enter the Network Settings page.
4	Using the center buttons for [+] or [-], adjust the <b>Network Addr</b> until it reads the desired network address.	Set all thermostats to a valid, unique address. Typically it is recommended to increment Thermostats sequentially (1, 2, 3 etc.)
5	Confirm <b>Network Type</b> is set to <b>RCS</b> and <b>Autosend</b> is set to <b>Y</b> .	If needed, use the [Up] and [Down] arrows to navigate and alter settings using the center buttons ([+] or [-]).

**Note: Each thermostat must be set to a unique address, even in mixed (tr40 and tr16) installs!**



## **COMMON MISTAKES**

1. Programming two thermostats with the same address.
2. Failing to plug the Cat5 cable assembly into the correct serial port. Make sure the RJ-45 connector is plugged into the correct serial port as specified in the Configurator.
3. Configuring 2 subsystems with the same serial port.
4. Incorrect serial type setting. The RCS Thermostat Network Communication Device has a drop down for RS-232 or RS-485. Set this appropriately. RS-485 connections should be set to RS-485 Half Duplex, RS-232 connections should be set to RS-232.